

Dimensions in centimetres.

PLAN

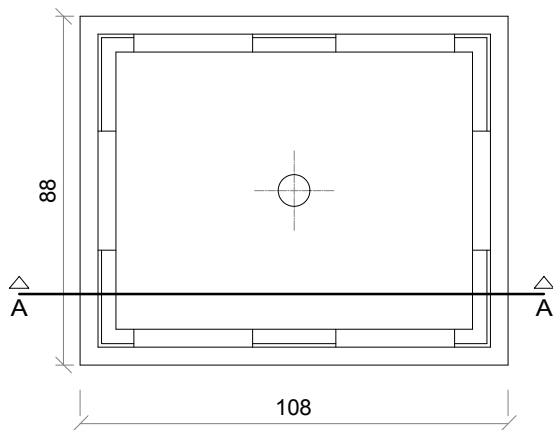

SECTION A-A

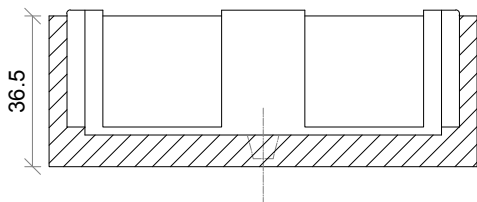

TYPICAL COMPOSITION

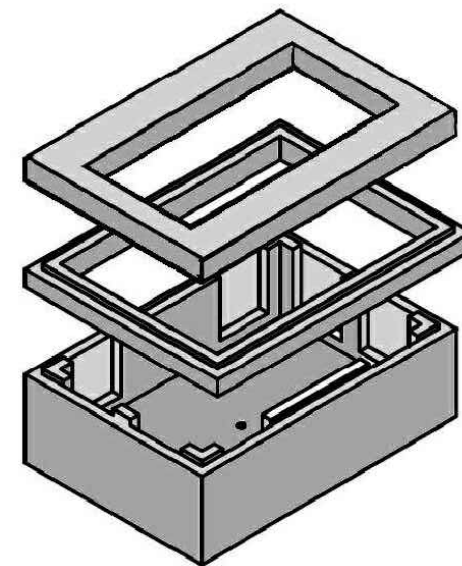
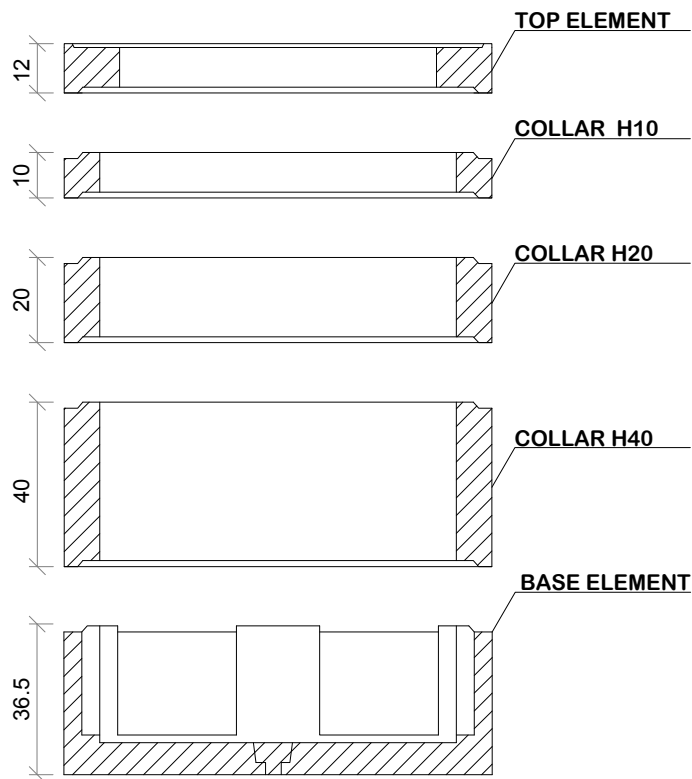

TECHNICAL DATA SHEET

CONCRETE STRENGTH :	C 32/40
CEMENT:	CEM 42.5 R
W/C RATIO max :	0.55
PRODUCTION TECHNOLOGY:	VIBRATION
BASE ELEMENT WEIGHT :	385 Kg
COLLAR H10 WEIGHT:	80 Kg
COLLAR H20 WEIGHT :	160 Kg
COLLAR H40 WEIGHT :	320 Kg
TOP ELEMENT 70x80 WEIGHT:	110 Kg
TOP ELEMENT 60x60 WEIGHT:	140 Kg
LINEAR TOLERANCE	± 3%
THICKNESS TOLERANCE	± 5%