

Dimensions in centimetres.

PLAN

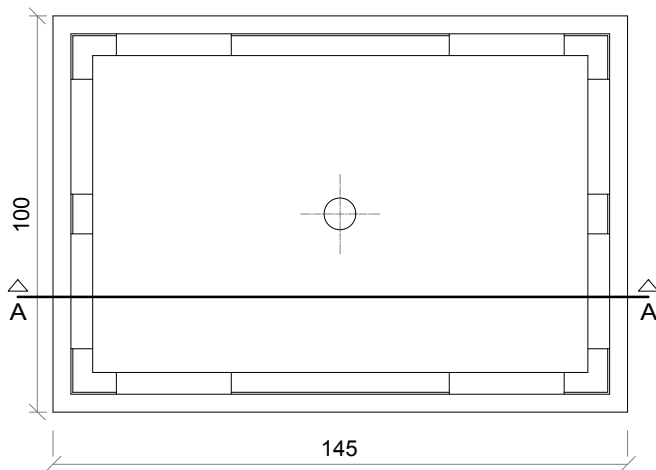

SECTION A-A

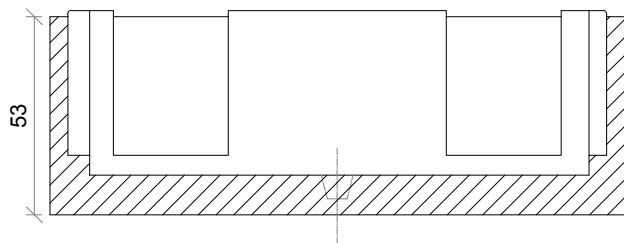

TYPICAL COMPOSITION

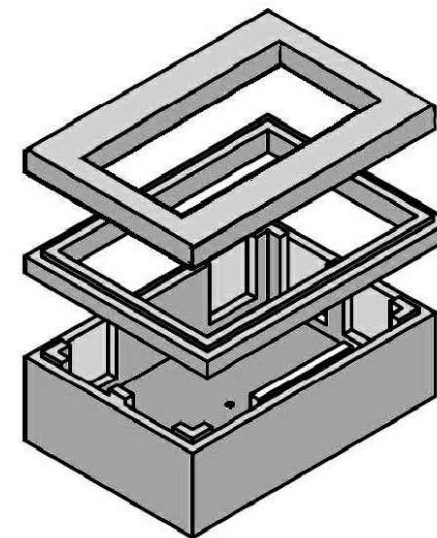
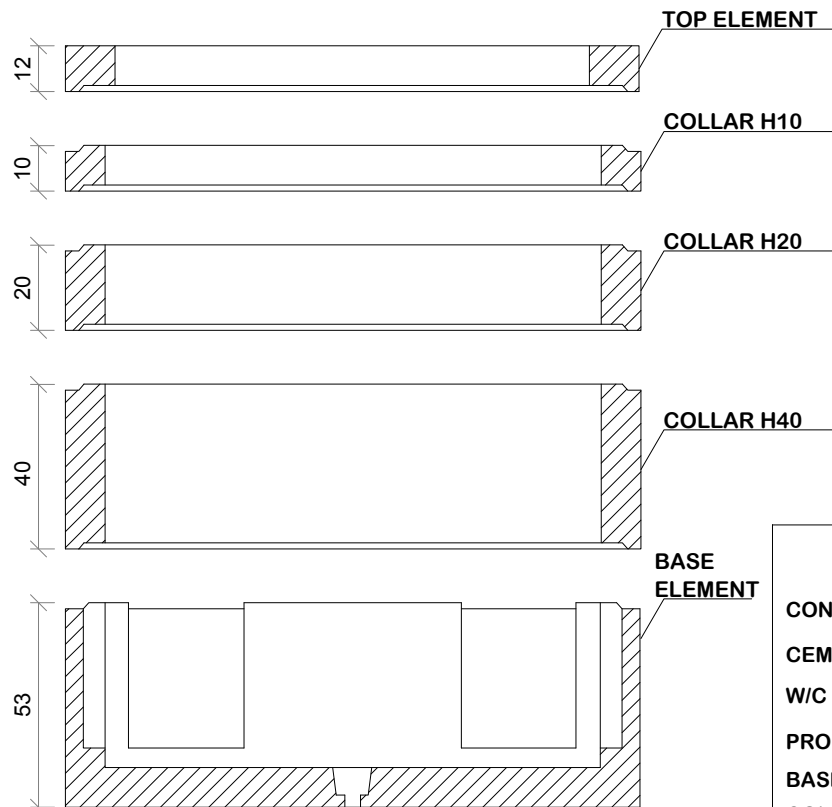

TECHNICAL DATA SHEET

CONCRETE STRENGTH :	C 32/40
CEMENT:	CEM 42.5 R
W/C RATIO max :	0.55
PRODUCTION TECHNOLOGY:	VIBRATION
BASE ELEMENT WEIGHT :	650 Kg
COLLAR H10 WEIGHT:	115 Kg
COLLAR H20 WEIGHT :	225 Kg
COLLAR H40 WEIGHT :	455 Kg
TOP ELEMENT 106X70 WEIGHT:	220 Kg
TOP ELEMENT 120X60 WEIGHT:	205 Kg
LINEAR TOLERANCE	± 3%
THICKNESS TOLERANCE	± 5%